

# BEST 400

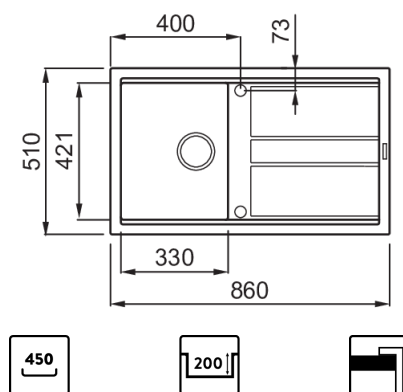

## Disegno tecnico



### CARATTERISTICHE PRODOTTO

<b>Descrizione</b>	Lavello 1 vasca con gocciolatoio
<b>Modello</b>	BEST 400
<b>Base (mm)</b>	450
<b>Installazioni</b>	Sopratop
<b>Dimensioni (mm)</b>	860 x 510
<b>Dimensioni Incasso (mm)</b>	840 x 480
<b>Numero Vasche</b>	1
<b>Profondità Vasca (mm)</b>	200

### DATI LOGISTICI

<b>Peso Lordo (kg)</b>	17,05
<b>Peso Netto (kg)</b>	11,20
<b>Dimensioni Imballo (kg)</b>	940 x 575 x 300
<b>Volume Imballo (kg)</b>	0,162

### CARATTERISTICHE IMBALLO

<b>Imballo</b>	Cartone e polietilene
<b>Corredi</b>	Sifone salvaspazio, FLOW PRO, troppopieno rettangolare e ganci.

## KERATEK<sup>plus</sup>

CERAMIC NANOTECHNOLOGY CN6

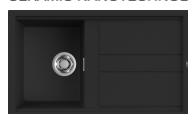

**LKB40086** K86  
8031873020057



**LKB40093** K93  
8031873026479



**LKB40095** K95  
8031873026486



**LKB40096** K96  
8031873020064



**LKB40097** K97  
8031873026493



**LKB40099** K99  
8031873026509

## GRANITEK<sup>®</sup>

NATURAL GRANITE EFFECT

METAL



**LMB40073** M73  
8032861953708

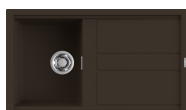

**LMB40078** M78  
8031873024079



**LMB40079** M79  
8032861953715

## GRANITEK<sup>®</sup>

NATURAL GRANITE EFFECT

MATT



**LGB40040** G40  
8032861047896



**LGB40043** G43  
8032861040897



**LGB40048** G48  
8032557030553



**LGB40068** G68  
8032861040873

**GRANITEK**<sup>®</sup>

NATURAL GRANITE EFFECT

CLASSIC



**LGB40051** G51  
8032861040750



**LGB40059** G59  
8032861047889

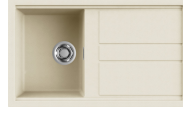

**LGB40062** G62  
8032861040743

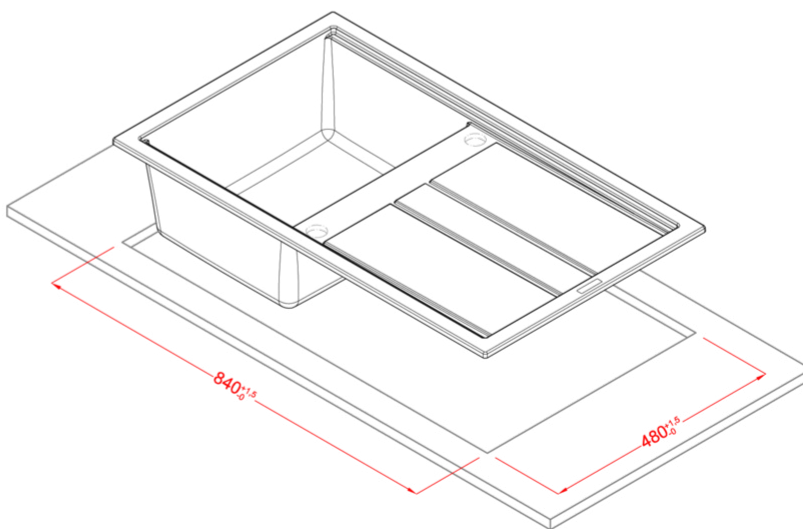
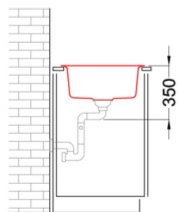
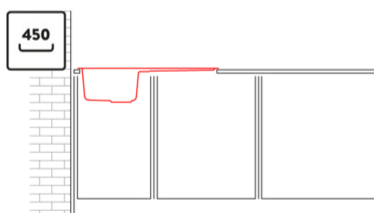
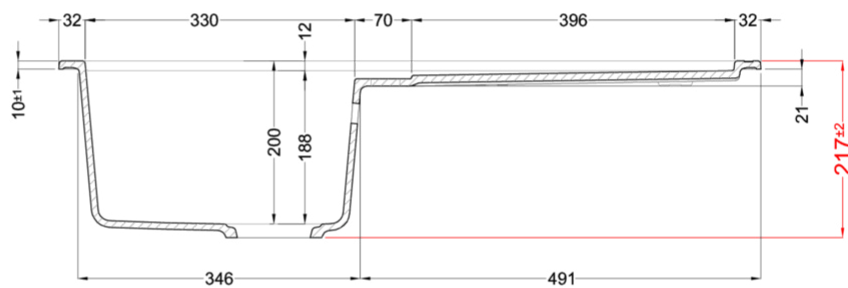
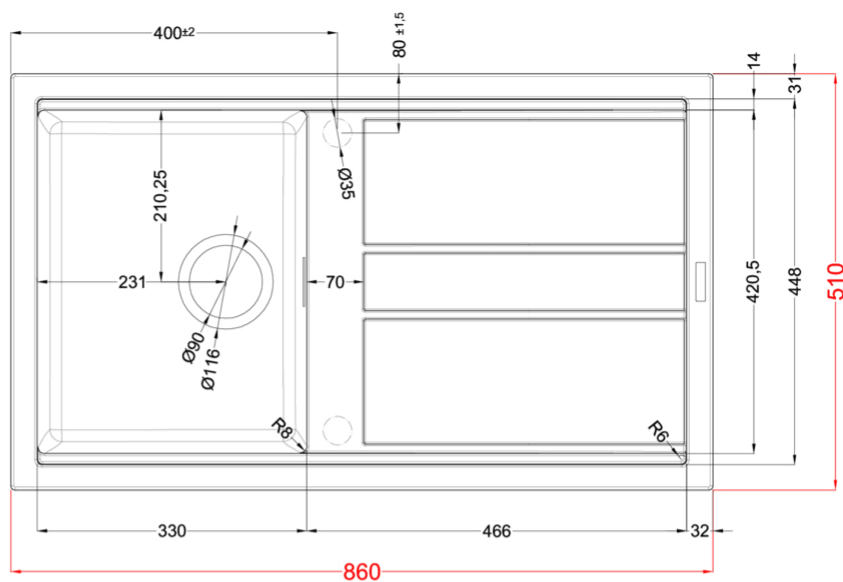
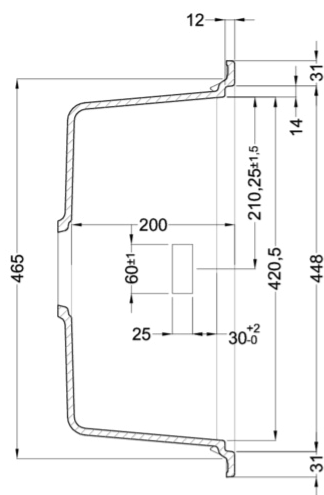

## BEST 400

general tolerances where not expressly communicated  $\pm 0.2\%$   
connection dimensions according to UNI EN 695

